

Finished Bore Sprockets



For Roller Chains DIN8187-ISO/R606

ALL sprockets are finished with induction hardened teeth.

This treatment gives a longer lasting life to sprockets.

And with finished bore, keyway and 2 grub

Screws, this eliminates further

modification by customer

and can be fitted

immediately.



Finished Bore Sprockets

Bore-Keyway-Screws

D(H7)	B(H9)	T	M
10	4	D+1.8 (+0.1/0)	M3
11	4	D+1.8 (+0.1/0)	M3
12	4	D+1.8 (+0.1/0)	M3
14	5	D+2.3 (+0.1/0)	M4
16	5	D+2.3 (+0.1/0)	M4
18	6	D+2.8 (+0.1/0)	M5
19	6	D+2.8 (+0.1/0)	M5
20	6	D+2.8 (+0.1/0)	M5
22	6	D+2.8 (+0.1/0)	M5
24	8	D+3.3 (+0.2/0)	M6
25	8	D+3.3 (+0.2/0)	M6
28	8	D+3.3 (+0.2/0)	M6
30	8	D+3.3 (+0.2/0)	M6
32	10	D+3.3 (+0.2/0)	M8
35	10	D+3.3 (+0.2/0)	M8
38	10	D+3.3 (+0.2/0)	M8
40	12	D+3.3 (+0.2/0)	M10
42	12	D+3.3 (+0.2/0)	M10
45	14	D+3.8 (+0.2/0)	M12
48	14	D+3.8 (+0.2/0)	M12
50	14	D+3.8 (+0.2/0)	M12
60	18	D+4.4 (+0.2/0)	M12
65	18	D+4.4 (+0.2/0)	M12
70	20	D+4.9 (+0.2/0)	M12

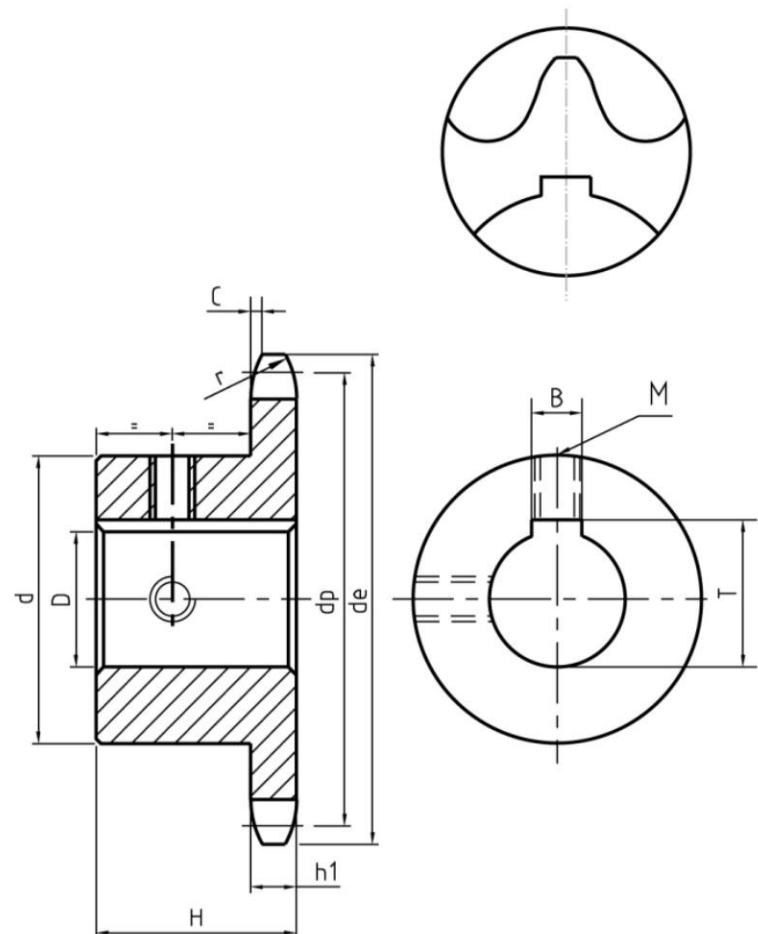

Finished Bore Sprockets



Finished Bore Sprockets

3/8" X 7/32"

CHAIN:	ISO
	mm
Pitch	9.525
Internal width	5.72
Roller Φ	6.35

SPROCKETS

Tooth radius r	10
Radius width C	1
Tooth width h ₁	5.3

06B-1 9.525 X 5.72mm

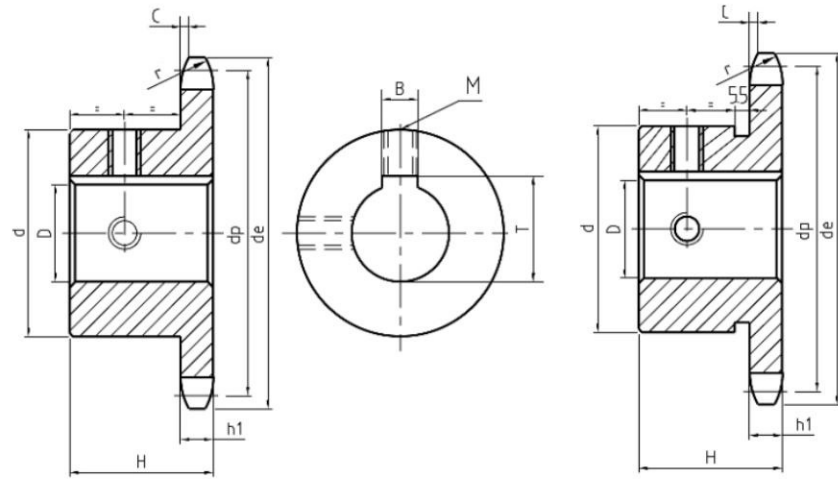

Type(*)

Material : C 45

Z	d _e	d _p	D	H	d
10	34	30.80	10	22	24
			11		26
			12		29
			14		29
11	37	33.8	10	25	24
			12		26
			14		29*
			16		31*
12	40	36.8	10	25	25
			12		26
			14		29
			16		31*
13	43	39.8	10	25	28
			12		29
			14		31
			16		35*
			18		35*
14	46.3	42.8	12	25	31
			14		35
			16		35
			18		35
15	49.3	45.81	12	25	34
			14		34
			16		34
			18		34
			19		35
			20		36
			22		38
16	52.3	48.82	12	28	37
			14		37
			16		37
			18		37
			20		37

Z	d _e	d _p	D	H	d
16	52.3	48.82	22	16	37
			24		42
			25		42
			12		40
			14		40
17	55.3	51.83	16	28	40
			18		40
			19		40
			20		40
			22		40
			24		40
			25		42
			12		43
			14		43
			16		43
18	58.3	54.85	12	28	43
			14		43
			16		43
			18		43
			19		43
			20		43
			22		43
			24		43
			25		43
			12		45
19	61.3	57.87	12	28	45
			14		45
			16		45
			18		45
			19		45
			20		45
			22		45
			24		45
			25		45
			12		46
20	64.3	60.89	12	28	46
			14		46
			16		46
			18		46
			19		46
			22		46

Z	d _e	d _p	D	H	d
20	64.3	60.89	24	28	46
			25		46
			16		46
21	68	63.91	18	28	48
			19		48
			20		48
			22		48
			24		48
			25		48
22	71	66.93	16	28	50
			18		50
			19		50
			20		50
			22		50
			24		50
23	73.5	69.95	16	28	52
			18		52
			19		52
			20		52
			22		52
24	77	72.97	16	28	54
			18		54
			19		54
			20		54
			22		54
			24		54
25	80	76	16	28	57
			18		57
			19		57
			20		57
			22		57
			24		57

Finished Bore Sprockets



1/2" X 5/16"

CHAIN:

Pitch	12.7
Internal width	7.75
Roller Φ	8.51

ISO
mm

SPROCKETS

Tooth radius r	13
Radius width C	1.3
Tooth width h ₁	7.2

08B-1 12.7 X 7.75mm

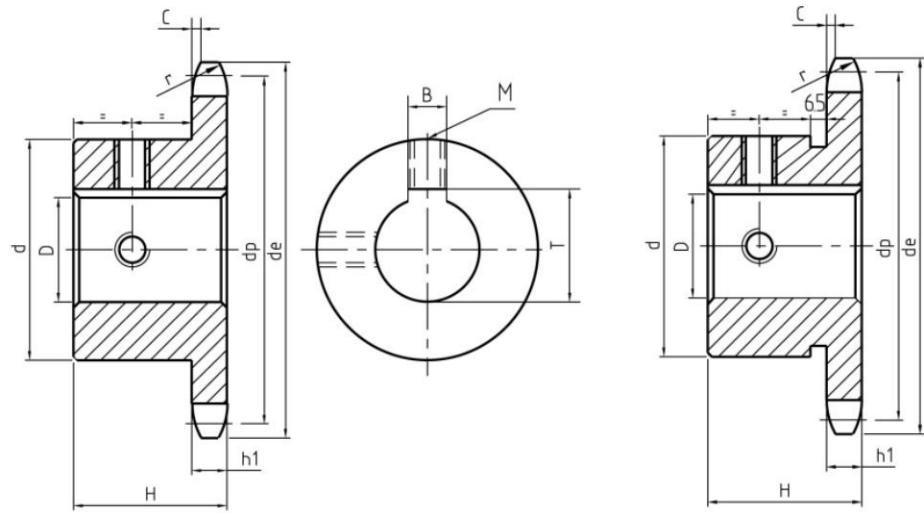

Material : C 45

Z	d _e	d _p	D	H	d
10	45.2	41.1	12	25	26
			14		29
			16		31
11	48.7	45.07	12	25	29
			14		31
			16		34
			18		35
			19		35
			20		35
12	53	49.07	12	28	33
			14		33
			16		33
			18		33
			19		35
			20		36
			22		38
			24		41*
			25		42*
			26		42*
13	57.4	53.06	12	28	37
			14		37
			16		37
			18		37
			19		37
			20		37
			22		42
			24		42
			25		45*
			28		45*
14	61.8	57.07	12	28	41
			14		41
			16		41
			18		41
			19		41
			20		41
			22		45
			24		45
			25		45
			28		45
15	65.5	61.09	12	28	45
			14		45
			16		45

Z	d _e	d _p	D	H	d
15	65.5	61.09	18	28	45
			19		45
			20		45
			22		45
			24		45
			25		45
			28		47
			30		49
16	69.5	65.1	16	28	50
			18		50
			19		50
			20		50
			22		50
			24		50
			25		50
			28		53
			30		53
			32		53
17	73.6	69.11	16	28	52
			18		52
			19		52
			20		52
			22		52
			24		52
			25		52
			28		56
			30		56
			32		56
18	77.8	73.14	16	28	56
			18		56
			19		56
			20		56
			22		56
			24		56
			25		56
			28		60
			30		60
			32		60

Z	d _e	d _p	D	H	d
18	77.8	73.14	38	28	56
			16		56
			18		56
			19		56
			20		56
			22		56
			24		56
			25		56
			28		60
			30		60
			32		60
			35		60
			38		60
19	81.7	77.16	24	28	60
			25		60
			28		60
			30		60
			32		60
			35		60
			38		60
			40		60
			42		60
			45		60
			48		60
			50		60
			52		60
20	85.8	81.19	16	28	64
			18		64
			19		64
			20		64
			22		64
			24		64
			25		64
			28		68
			30		68
			32		68
			35		68
			38		68
			40		68
21	89.7	85.22	24	28	68
			25		68
			28		68
			30		68
			32		68
			35		68
			38		68
			40		68
			42		68
			45		68
			48		68
			50		68
			52		68

Z	d _e	d _p	D	H	d
22	93.8	89.24	20	28	70
			22		70
			24		70
			25		70
			28		70
			30		70
			32		70
			35		70
			38		70
			40		70
			42		70
			45		70
			23		98.2
28	70				
30	70				
32	70				
35	70				
38	70				
40	70				
42	70				
45	70				
48	70				
50	70				
52	70				
24	101.8	97.29		28	
			30	70	
			32	70	
			35	70	
			38	70	
			40	70	
			42	70	
			45	70	
			48	70	
			50	70	
			52	70	
			54	70	
			25	105.8	101.33
28	70				
30	70				
32	70				
35	70				
38	70				
40	70				
42	70				
45	70				
48	70				
50	70				
52	70				
54	70				

Finished Bore Sprockets



Finished Bore Sprockets

5/8" X 3/8"

CHAIN:	ISO mm
Pitch	15.875
Internal width	9.65
Roller Φ	10.16

SPROCKETS

Tooth radius r	16
Radius width C	1.6
Tooth width h_1	9.1

10B-1 15.875 X 9.65mm

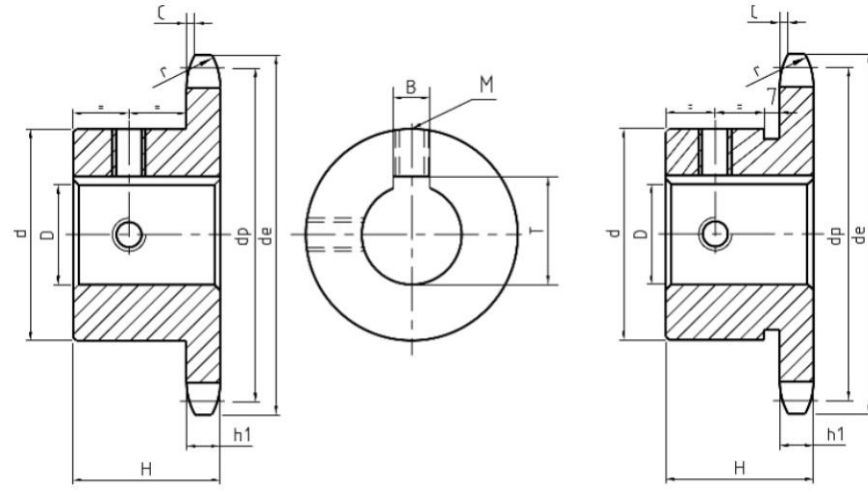

Type(*)

Material : C 45

Z	d _e	d _p	D	H	d
10	57.5	51.37	16	25	35
			19		
			20		
			24		
			42*		
11	63	56.34	16	30	37
			18		
			19		
			20		
			24		
			42		
12	68	61.34	25	30	45
			28		
			16		
			18		
			19		
			20		
			22		
			24		
13	73	66.32	25	30	47
			28		
			30		
			32		
			16		
			18		
			19		
			20		
			22		
			24		
14	78	71.34	25	30	52
			28		
			30		
			32		
			16		
			18		
			19		
			20		
			22		
			24		
15	83	76.36	19	30	57
			20		
			22		
			24		
			25		

Z	d _e	d _p	D	H	d
15	83	76.36	20	30	57
			22		
			24		
			25		
			28		
			30		
			32		
			35		
			19		
			20		
16	88	81.37	19	30	60
			20		
			22		
			24		
			25		
			28		
			30		
			32		
			35		
			38		
17	93	86.39	19	30	60
			20		
			22		
			24		
			25		
			28		
			30		
			32		
			35		
			38		
18	98.3	91.42	19	30	70
			20		
			22		
			24		
			25		
			28		
			30		
			32		
			35		
			38		
19	103.3	96.45	19	30	70
			20		
			22		
			24		
			25		

Z	d _e	d _p	D	H	d
19	103.3	96.45	22	30	70
			24		
			25		
			28		
			30		
			32		
			35		
			38		
			40		
			42		
20	108.4	101.49	19	30	75
			20		
			22		
			24		
			25		
			28		
			30		
			32		
			35		
			38		
21	113.4	106.52	19	30	75
			20		
			22		
			24		
			25		
			28		
			30		
			32		
			35		
			38		
22	118	111.55	19	30	80
			20		
			22		
			24		
			25		
			28		
			30		
			32		
			35		
			38		

Z	d _e	d _p	D	H	d
22	118	111.55	35	30	80
			38		
			40		
			42		
			19		
23	123.4	116.58	20	30	80
			22		
			24		
			25		
			28		
			30		
			32		
			35		
			38		
			40		
24	128.3	121.62	19	30	80
			20		
			22		
			24		
			25		
			28		
			30		
			32		
			35		
			38		
25	134	126.66	19	30	80
			20		
			22		
			24		
			25		
			28		
			30		
			32		
			35		
			38		
25	134	126.66	40	30	80
			42		

Finished Bore Sprockets



3/4" X 7/16"

CHAIN:

	ISO mm
Pitch	19.05
Internal width	11.68
Roller Φ	12.07

SPROCKETS

Tooth radius r	19
Radius width C	2
Tooth width h ₁	11.1

12B-1 19.05 X 11.68mm

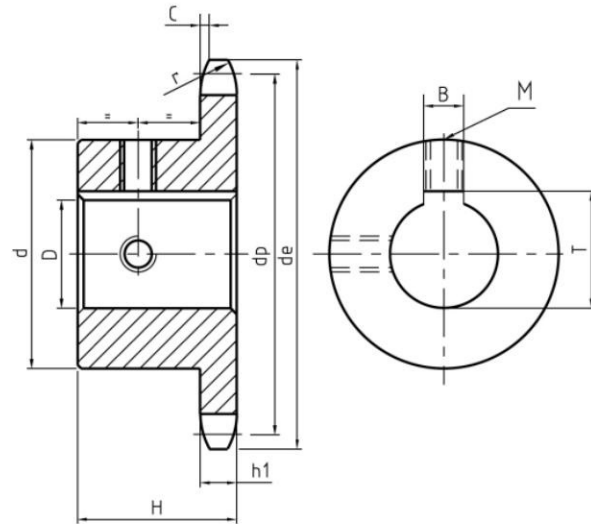

Material : C 45

Z	d _e	d _p	D	H	d	
10	69	61.64	19	30	42	
			20			
			24			
			25			
			28			45
			30			47
			32			49
11	75	67.61	19	35	48	
			20			
			24			
			25			
			28			49
			30			51
			32			53
12	81.5	73.6	19	35	52	
			20			
			22			
			24			
			25			
			28			53
			30			56
13	87.5	79.59	19	35	58	
			20			
			22			
			24			
			25			
			28			
			30			
32						
14	93.6	85.61	19	35	64	
			20			
			22			
			24			
			25			
			28			
			30			

Z	d _e	d _p	D	H	d	
14	93.6	85.61	32	35	64	
			35			
			38			
			40			
			19			67
			20			
			22			
15	99.8	91.63	24	35	70	
			25			
			28			
			30			
			32			
			35			
			38			
16	105.5	97.65	40	35	75	
			19			
			20			
			22			
			24			
			25			
			28			
17	115.5	103.67	32	35	80	
			35			
			38			
			40			
			25			
			28			
			30			
18	118	109.71	25	35	80	
			28			
			30			
			32			
			35			
			38			
			40			

Z	d _e	d _p	D	H	d
18	118	109.71	40	35	80
			42		
			25		
			28		
			30		
			32		
			35		
19	124.2	115.75	38	35	80
			40		
			42		
			45		
			48		
			50		
			55		
20	129.7	121.78	25	35	80
			28		
			30		
			32		
			35		
			38		
			40		
21	136	127.82	42	35	90
			45		
			48		
			50		
			25		
			28		
			30		
22	141.8	133.86	32	40	90
			35		

Z	d _e	d _p	D	H	d
22	141.8	133.86	38	40	90
			40		
			42		
			45		
			48		
			50		
			25		
23	149	139.9	25	40	90
			28		
			30		
			32		
			35		
			38		
			40		
24	153.9	145.94	42	40	90
			45		
			48		
			50		
			25		
			28		
			30		
25	160	152	32	40	90
			35		
			38		
			40		
			42		
			45		
			48		

Finished Bore Sprockets

Finished Bore Sprockets



Finished Bore Sprockets

1" X17.02

CHAIN:

Pitch	25.4
Internal width	17.02
Roller ϕ	15.88

ISO mm

SPROCKETS

Tooth radius r	26
Radius width C	2.5
Tooth width h_1	16.2

16B-1 25.4 X 17.02mm

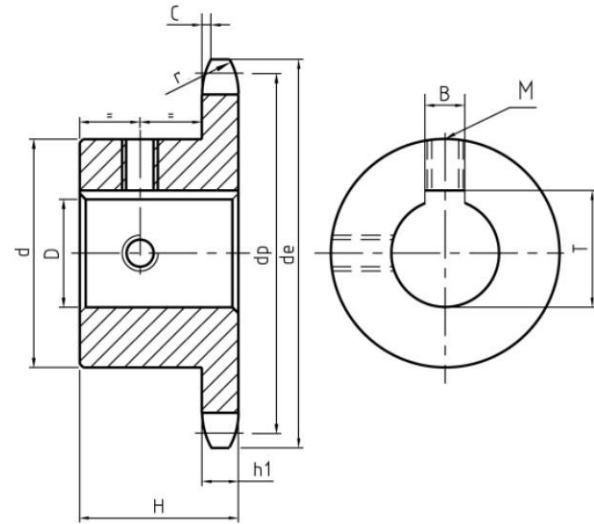

Material : C 45

Z	d _e	d _p	D	H	d
11	99.5	90.14	25	40	61
			28		
			30		
			32		
			35		
			38		
			40		
			42		
			65		
			67		
69					
12	109	98.14	25	40	69
			28		
			30		
			32		
			35		
			38		
			40		
			42		
			45		
			48		
50					
13	117	106.12	25	40	78
			28		
			30		
			32		
			35		
			38		
			40		
			42		
			45		
			48		
50					
14	125	114.15	25	40	84
			28		
			30		
			32		
			35		
			38		
			40		
			42		
			45		
			48		
50					
15	133	122.17	25	40	92
			28		
			30		

Z	d _e	d _p	D	H	d
15	133	122.17	30	40	92
			32		
			35		
			38		
			40		
			42		
			45		
			48		
			50		
			55		
16	141	130.2	25	45	100
			28		
			30		
			32		
			35		
			38		
			40		
			42		
			45		
			48		
17	149	138.22	25	45	100
			28		
			30		
			32		
			35		
			38		
			40		
			42		
			45		
			48		
18	157	146.28	25	45	100
			28		
			30		
			32		
			35		
			38		
			40		
			42		
			45		
			48		

Z	d _e	d _p	D	H	d
18	157	146.28	48	45	100
			50		
			25		
			28		
			30		
			32		
			35		
			38		
			40		
			42		
19	165.2	154.33	25	45	100
			28		
			30		
			32		
			35		
			38		
			40		
			42		
			45		
			48		
20	173.2	162.38	25	45	100
			28		
			30		
			32		
			35		
			38		
			40		
			42		
			45		
			48		
21	181.2	170.43	25	45	110
			28		
			30		
			32		
			35		
			38		
			40		
			42		
			45		
			48		
22	189.3	178.48	25	45	110
			28		
			30		
			32		
			35		

Z	d _e	d _p	D	H	d
22	189.3	178.48	38	50	110
			40		
			42		
			45		
			48		
			50		
			25		
			28		
			30		
			32		
23	197.5	186.53	35	50	110
			38		
			40		
			42		
			45		
			48		
			50		
			25		
			28		
			30		
24	205.5	194.59	32	50	110
			35		
			38		
			40		
			42		
			45		
			48		
			50		
			25		
			28		
25	213.5	202.66	30	50	110
			32		
			35		
			38		
			40		
			42		
			45		
			48		
			50		
			55		

Finished Bore Sprockets



1" 1/4 X 3/4"

CHAIN:

	ISO mm
Pitch	31.75
Internal width	19.56
Roller ϕ	19.05

SPROCKETS

Tooth radius r	32
Radius width C	3.5
Tooth width h ₁	18.5

20B-1 31.75 X 19.56mm

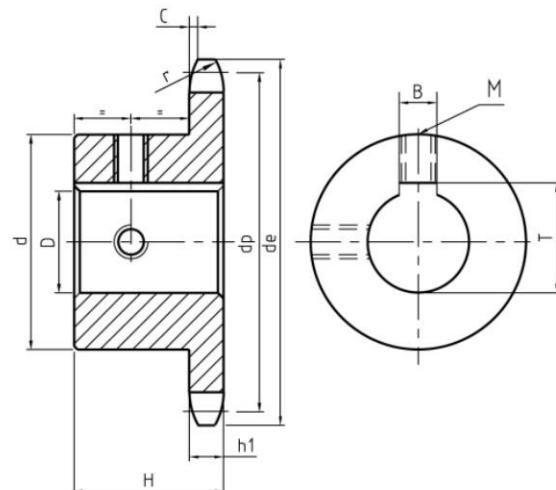

Finished Bore Sprockets

Material : C 45

Z	d _e	d _p	D	H	d	
09	108	92.84	25	40	63	
			30			
			32			
			35			
			38			
10	117.9	102.74	25	40	70	
			30			
			32			
			35			
			38			
11	127.8	112.68	25	45	77	
			28			
			30			
			32			
			35			
			38			
			40			
			42			
			45			
			50			82
			60			93
12	137.8	122.68	25	45	88	
			28			
			30			
			32			
			35			
			38			
			40			
			42			
			45			
			60			93
13	147.8	132.65	25	45	98	
			28			
			31			

Z	d _e	d _p	D	H	d
13	147.8	132.65	32	45	98
			35		
			38		
			40		
			42		
			45		
			48		
			50		
			60		
			14		
35					
38					
40					
42					
45					
48					
50					
60					
15	167.9	152.72		32	45
			35		
			38		
			40		
			42		
			45		
			48		
			50		
			60		
			16	177.9	
40					
42					
45					
48					
50					
60					
65					
70					

Z	d _e	d _p	D	H	d
17	187.9	172.78	38	50	120
			40		
			42		
			45		
			48		
			50		
			60		
			65		
			70		
			18		
40					
42					
45					
48					
50					
60					
65					
70					
19	208.1	192.91		38	50
			40		
			42		
			45		
			48		
			50		
			60		
			65		
			70		
			20	218.1	
40					
42					
45					
48					
50					
60					
65					
70					