

PILOT BORED
V-BELT PULLEYS

SPZ/1

Product Model	P	O	Grooves	N	L	D	S	B	TYPE	d (H9)	Weight (Kg)
SPZ45-1	45	49	1	40	28			16	1	10	0.25
SPZ50-1	50	54	1	40	28			16	1	10	0.25
SPZ56-1	56	60	1	45	28			16	1	10	0.36
SPZ63-1	63	67	1	50	28			16	1	10	0.47
SPZ71-1	71	75	1	50	28			16	1	10	0.56
SPZ75-1	75	79	1	50	28			16	1	10	0.60
SPZ80-1	80	84	1	50	28			16	1	10	0.67
SPZ85-1	85	89	1	50	28			16	1	10	0.75
SPZ90-1	90	94	1	50	28			16	1	10	0.82
SPZ95-1	95	99	1	50	28			16	1	10	0.90
SPZ100-1	100	104	1	50	28			16	1	10	0.99
SPZ106-1	106	110	1	50	28			16	1	10	1.10
SPZ112-1	112	116	1	50	28			16	1	10	1.21
SPZ118-1	118	122	1	50	28	93	8	16	3	10	1.05
SPZ125-1	125	129	1	50	28	100	8	16	3	15	1.12
SPZ132-1	132	136	1	50	28	106	8	16	3	15	1.24
SPZ140-1	140	144	1	50	28	114	8	16	3	15	1.34
SPZ150-1	150	154	1	50	28	124	8	16	3	15	1.49
SPZ160-1	160	164	1	55	32	134	8	16	3	15	1.78
SPZ170-1	170	174	1	55	32	144	8	16	3	15	1.92
SPZ180-1	180	184	1	55	32	154	8	16	5	20	1.57
SPZ190-1	190	194	1	55	32	164	8	16	5	20	1.60
SPZ200-1	200	204	1	55	32	174	8	16	5	20	1.73
SPZ212-1	212	216	1	55	32	186	8	16	5	20	1.80
SPZ224-1	224	228	1	55	32	198	8	16	5	20	1.88
SPZ250-1	250	254	1	55	32	224	8	16	5	20	2.13
SPZ280-1	280	284	1	55	32	254	8	16	5	20	2.40
SPZ315-1	315	319	1	55	32	289	10	16	5	20	2.98
SPZ355-1	355	359	1	60	32	328	10	16	5	20	3.10

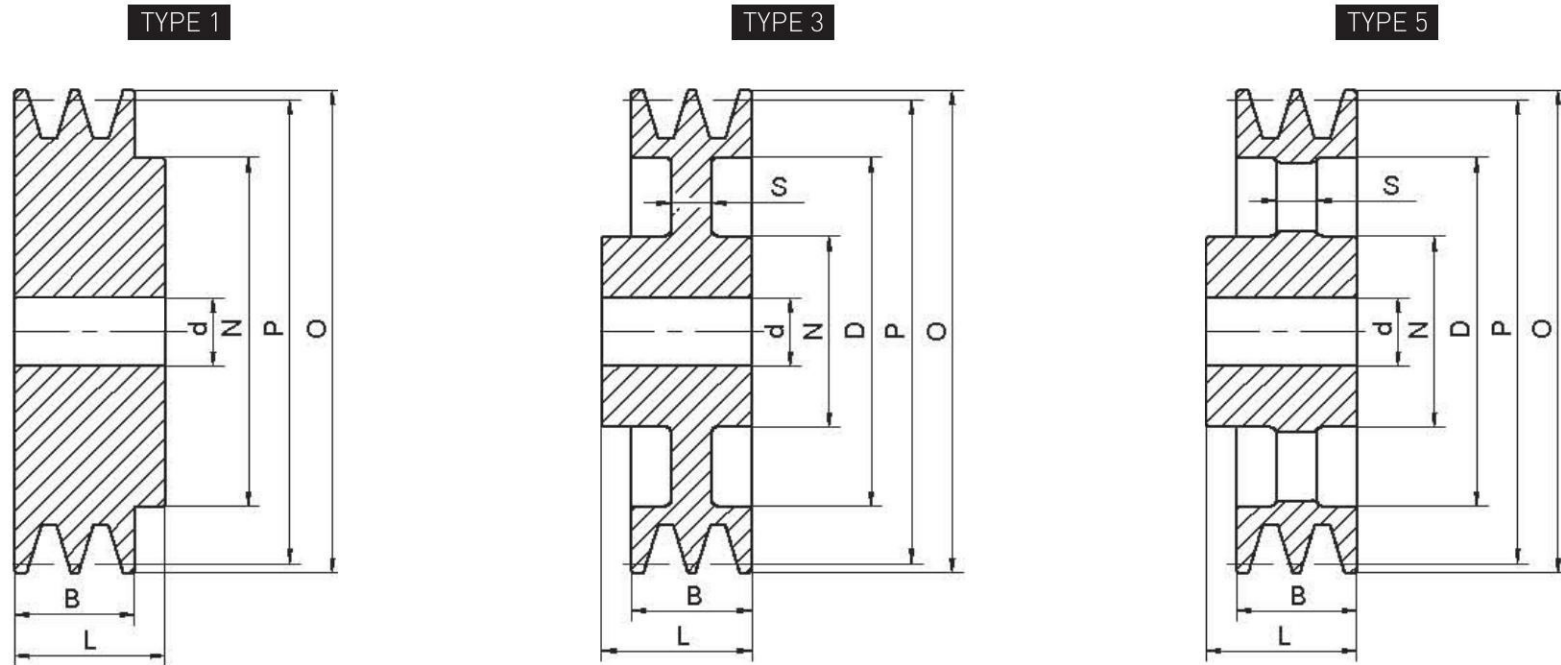

SPZ/2

Product Model	P	O	Grooves	N	L	D	S	B	TYPE	d (H9)	Weight (Kg)
SPZ45-2	45	49	2	40	35			28	1	10	0.30
SPZ50-2	50	54	2	40	35			28	1	10	0.36
SPZ56-2	56	60	2	45	35			28	1	10	0.47
SPZ63-2	63	67	2	50	35			28	1	10	0.60
SPZ67-2	67	71	2	50	35			28	1	10	0.67
SPZ71-2	71	75	2	55	35			28	1	10	0.78
SPZ75-2	75	79	2	60	35			28	1	10	0.89
SPZ80-2	80	84	2	60	35			28	1	10	1.00
SPZ85-2	85	89	2	60	35			28	1	10	1.14
SPZ90-2	90	94	2	60	35			28	1	10	1.28
SPZ95-2	95	99	2	60	35			28	1	15	1.39
SPZ100-2	100	104	2	60	35			28	1	15	1.53
SPZ106-2	106	110	2	60	35			28	1	15	1.72
SPZ112-2	112	116	2	60	35			28	1	15	1.91
SPZ118-2	118	122	2	60	35	91	8	28	3	15	1.58
SPZ125-2	125	129	2	60	35	99	8	28	3	15	1.69
SPZ132-2	132	136	2	60	40	106	8	28	3	15	1.89
SPZ140-2	140	144	2	60	40	114	8	28	3	15	2.04
SPZ150-2	150	154	2	60	40	124	8	28	3	15	2.19
SPZ160-2	160	164	2	60	40	134	8	28	3	15	2.23
SPZ170-2	170	174	2	60	40	144	8	28	3	15	2.26
SPZ180-2	180	184	2	60	40	154	8	28	5	20	2.29
SPZ190-2	190	194	2	60	40	164	8	28	5	20	2.38
SPZ200-2	200	204	2	60	40	174	8	28	5	20	2.49
SPZ212-2	212	216	2	60	40	186	8	28	5	20	2.62
SPZ224-2	224	228	2	60	40	198	8	28	5	20	2.76
SPZ250-2	250	254	2	60	40	224	10	28	5	20	3.52
SPZ280-2	280	284	2	65	45	254	10	28	5	20	3.85
SPZ315-2	315	319	2	65	45	289	10	28	5	20	4.40
SPZ355-2	355	359	2	68	45	328	12	28	5	20	5.50
SPZ400-2	400	404	2	75	45	372	12	28	5	20	6.50

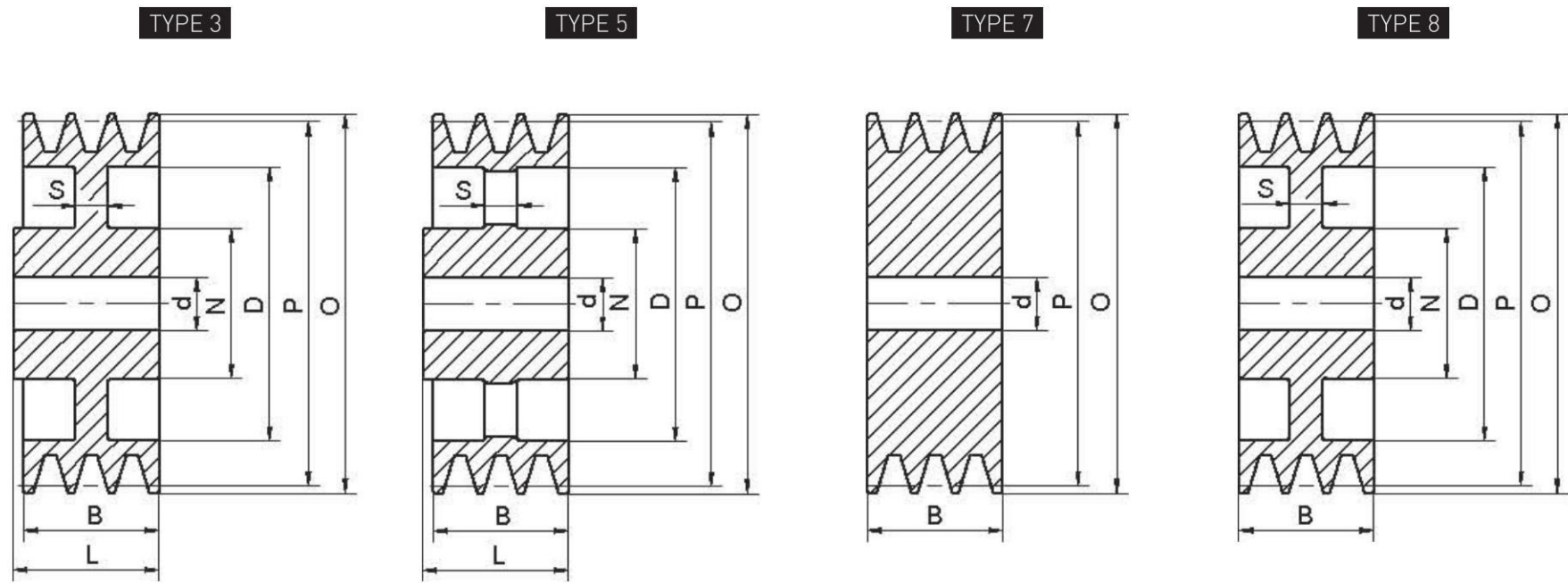

PILOT BORED
V-BELT PULLEYS

SPZ/3

Product Model	P	O	Grooves	N	L	D	S	B	TYPE	d (H9)	Weight (Kg)
SPZ50-3	50	54	3					40	7	10	0.42
SPZ56-3	56	60	3					40	7	10	0.55
SPZ63-3	63	67	3					40	7	10	0.71
SPZ71-3	71	75	3					40	7	10	0.94
SPZ75-3	75	79	3					40	7	10	1.06
SPZ80-3	80	84	3					40	7	10	1.22
SPZ85-3	85	89	3					40	7	15	1.34
SPZ90-3	90	94	3					40	7	15	1.57
SPZ95-3	95	99	3					40	7	15	1.75
SPZ100-3	100	104	3					40	7	15	1.95
SPZ106-3	106	110	3					40	7	15	2.23
SPZ112-3	112	116	3					40	7	15	2.50
SPZ118-3	118	122	3					40	7	15	2.82
SPZ125-3	125	129	3					40	7	15	3.18
SPZ132-3	132	136	3	60	40	106	8	40	8	15	2.19
SPZ140-3	140	144	3	60	40	114	8	40	8	15	2.33
SPZ150-3	150	154	3	60	40	124	8	40	8	20	2.51
SPZ160-3	160	164	3	65	45	134	8	40	3	20	2.70
SPZ170-3	170	174	3	65	45	144	8	40	3	20	2.86
SPZ180-3	180	184	3	65	45	154	8	40	5	20	3.00
SPZ190-3	190	194	3	65	45	164	10	40	5	20	3.10
SPZ200-3	200	204	3	65	45	174	10	40	5	20	3.28
SPZ212-3	212	216	3	65	45	186	10	40	5	20	3.50
SPZ224-3	224	228	3	65	45	198	10	40	5	20	3.76
SPZ250-3	250	254	3	65	45	224	12	40	5	20	4.33
SPZ280-3	280	284	3	65	45	254	12	40	5	20	5.50
SPZ315-3	315	319	3	65	45	289	12	40	5	20	7.00
SPZ355-3	355	359	3	80	50	328	12	40	5	20	8.50
SPZ400-3	400	404	3	80	50	372	12	40	5	20	10.00