

Taper Bore Sprockets

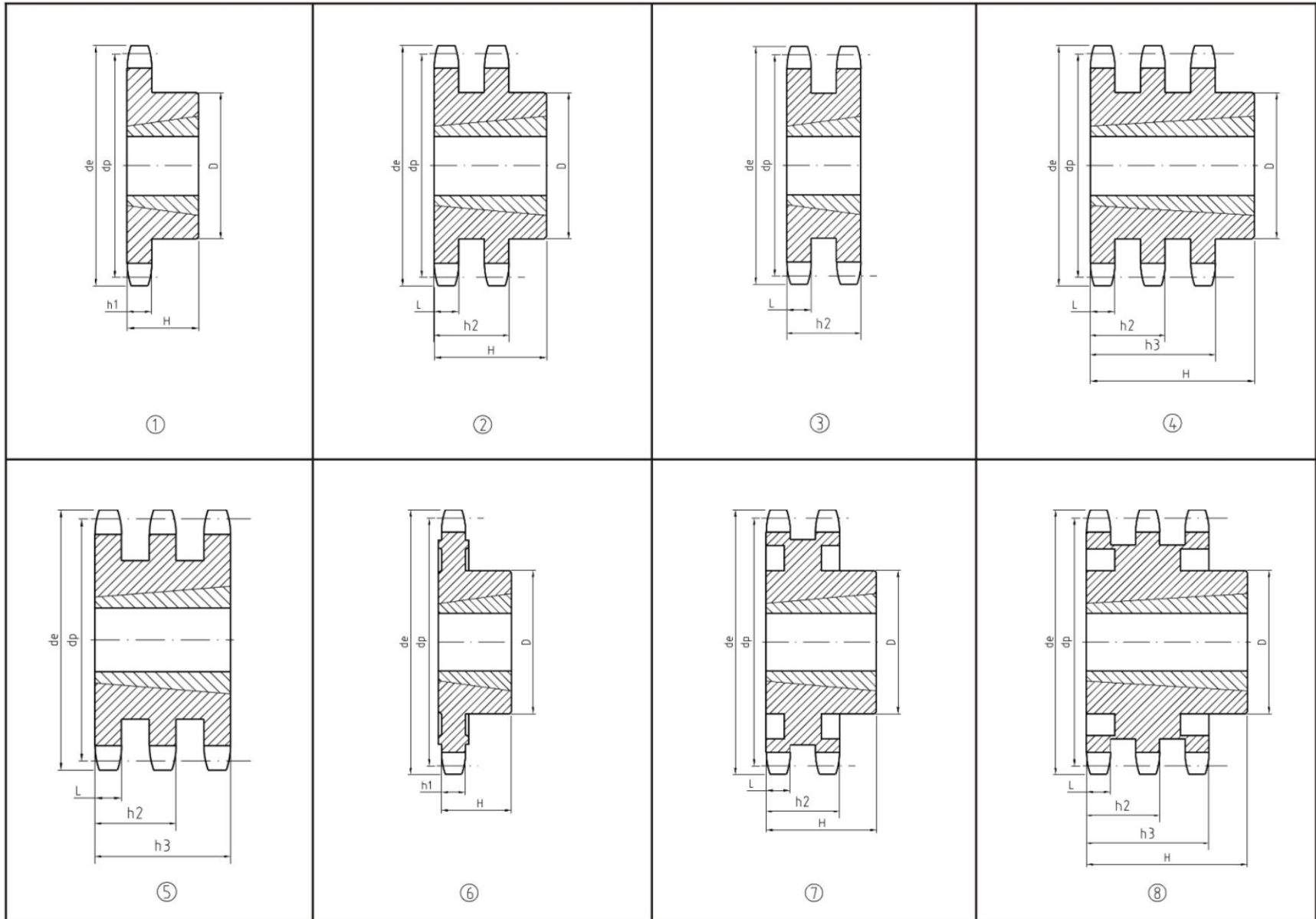

For Roller Chains DIN8187-ISO/R606



Taper Bore Sprockets

3/8" X7/32"

Steel=C45
*Cast iron=G22

06B-1-2-3 9.525X5.72mm

| CHAIN: | ISO mm |
|----------------|--------|
| Pitch | 9.525 |
| Internal width | 5.72 |
| Roller Φ | 6.35 |

DIN 8187 ISO/R 606

| SPROCKETS | ISO mm |
|-------------------|--------|
| Tooth radius r | 10 |
| Radius width C | 1 |
| Tooth width h_1 | 5.3 |
| Tooth width L | 5.2 |
| Tooth width h_2 | 15.4 |
| Tooth width h_3 | 25.6 |

| Z | de | dp | TS | | | | TD | | | | TT | | | |
|------|-------|--------|----|----|----------|------|----|----|----------|------|----|------|----------|------|
| | | | D | H | for Bush | Type | D | H | for Bush | Type | D | H | for Bush | Type |
| 17 | 55.3 | 51.83 | 45 | 22 | 1008 | 1 | 41 | 22 | 1008 | 2 | - | 25.6 | 1008 | 5 |
| 19 | 61.3 | 57.87 | 45 | 22 | 1008 | 1 | 46 | 22 | 1008 | 2 | - | 25.6 | 1008 | 5 |
| 21 | 68.0 | 63.91 | 46 | 22 | 1008 | 1 | 49 | 22 | 1008 | 2 | - | 25.6 | 1008 | 5 |
| 23 | 73.5 | 69.95 | 63 | 25 | 1210 | 1 | 59 | 25 | 1210 | 2 | - | 25.6 | 1210 | 5 |
| 25 | 80.0 | 76.02 | 63 | 25 | 1210 | 1 | 64 | 25 | 1210 | 2 | - | 25.6 | 1210 | 5 |
| 27 | 86.0 | 82.20 | 63 | 25 | 1210 | 1 | 70 | 25 | 1210 | 2 | - | 25.6 | 1210 | 5 |
| 30 | 94.7 | 91.12 | 63 | 25 | 1210 | 1 | 75 | 25 | 1210 | 2 | 79 | 38 | 1615 | 4 |
| *38 | 119.5 | 115.35 | 70 | 25 | 1210 | 1 | 80 | 25 | 1610 | 2 | 90 | 38 | 1615 | 4 |
| *45 | 140.7 | 136.55 | 70 | 25 | 1210 | 1 | 80 | 25 | 1610 | 2 | | | | |
| *57 | 176.9 | 172.91 | 70 | 25 | 1210 | 6 | 80 | 25 | 1610 | 7 | | | | |
| *76 | 234.9 | 230.49 | 70 | 25 | 1210 | 6 | 80 | 25 | 1610 | 7 | | | | |
| *95 | 292.5 | 288.08 | 80 | 25 | 1210 | 6 | 90 | 25 | 1610 | 7 | | | | |
| *114 | 349.5 | 345.68 | 80 | 25 | 1210 | 6 | 95 | 38 | 1615 | 7 | | | | |

Taper Bore Sprockets



Taper Bore Sprockets

1/2" X5/16"

08B-1-2-3 12.5X7.75mm

DIN 8187 ISO/R 606

| CHAIN: | ISO mm |
|----------------|--------|
| Pitch | 12.7 |
| Internal width | 7.75 |
| Roller Φ | 8.51 |

| SPROCKETS | ISO mm |
|-------------------|--------|
| Tooth radius r | 13 |
| Radius width C | 1.3 |
| Tooth width h_1 | 7.2 |
| Tooth width L | 7 |
| Tooth width h_2 | 21 |
| Tooth width h_3 | 34.9 |

Steel=C45
*Cast iron=G22

| Z | de | dp | TS | | | | TD | | | | TT | | | |
|------|-------|--------|-----|----|----------|------|-----|----|----------|------|----|------|----------|------|
| | | | D | H | for Bush | Type | D | H | for Bush | Type | D | H | for Bush | Type |
| 15 | 65.5 | 61.90 | 45 | 22 | 1008 | 1 | 46 | 22 | 1008 | 2 | - | 34.9 | 1008 | 5 |
| 17 | 73.6 | 69.11 | 60 | 25 | 1210 | 1 | 56 | 25 | 1210 | 2 | - | 34.9 | 1210 | 5 |
| 19 | 81.7 | 77.16 | 63 | 25 | 1210 | 1 | 62 | 25 | 1210 | 2 | - | 34.9 | 1210 | 5 |
| 21 | 89.7 | 85.22 | 71 | 25 | 1610 | 1 | 70 | 25 | 1610 | 2 | - | 34.9 | 1610 | 5 |
| 23 | 98.2 | 93.27 | 76 | 25 | 1610 | 1 | 79 | 25 | 1610 | 2 | - | 34.9 | 1610 | 5 |
| 25 | 105.8 | 101.33 | 76 | 25 | 1610 | 1 | 87 | 32 | 2012 | 2 | - | 34.9 | 2012 | 5 |
| 27 | 114.0 | 109.40 | 76 | 25 | 1610 | 1 | 87 | 32 | 2012 | 2 | - | 34.9 | 2012 | 5 |
| 30 | 126.1 | 121.50 | 90 | 32 | 2012 | 1 | 87 | 32 | 2012 | 2 | - | 34.9 | 2012 | 5 |
| 38 | 158.6 | 153.80 | 90 | 32 | 2012 | 1 | 100 | 32 | 2012 | 2 | - | 34.9 | 2012 | 5 |
| *45 | 188.0 | 182.07 | 100 | 32 | 2012 | 1 | 100 | 32 | 2012 | 2 | - | 34.9 | 2012 | 5 |
| *57 | 236.4 | 230.54 | 100 | 32 | 2012 | 6 | 100 | 32 | 2012 | 7 | - | 34.9 | 2012 | 5 |
| *76 | 313.3 | 307.33 | 100 | 32 | 2012 | 6 | 100 | 32 | 2012 | 7 | - | 34.9 | 2012 | 5 |
| *95 | 390.1 | 384.11 | 100 | 32 | 2012 | 6 | 100 | 32 | 2012 | 7 | - | 34.9 | 2012 | 5 |
| *114 | 466.9 | 460.90 | 110 | 45 | 2517 | 6 | 110 | 45 | 2517 | 7 | - | 34.9 | 2012 | 5 |

5/8" X3/8"

10B-1-2-3 15.857X9.65mm

DIN 8187 ISO/R 606

| CHAIN: | ISO mm |
|----------------|--------|
| Pitch | 15.875 |
| Internal width | 9.65 |
| Roller Φ | 10.16 |

| SPROCKETS | ISO mm |
|-------------------|--------|
| Tooth radius r | 16 |
| Radius width C | 1.6 |
| Tooth width h_1 | 9.1 |
| Tooth width L | 9 |
| Tooth width h_2 | 25.5 |
| Tooth width h_3 | 42.1 |

Steel=C45
*Cast iron=G22

| Z | de | dp | TS | | | | TD | | | | TT | | | |
|------|-------|--------|-----|----|----------|------|----|------|----------|------|-----|------|----------|------|
| | | | D | H | for Bush | Type | D | H | for Bush | Type | D | H | for Bush | Type |
| 13 | 73.0 | 66.32 | 47 | 22 | 1008 | 1 | - | 25.5 | 1210 | 3 | - | 42.1 | 1210 | 5 |
| 15 | 83.0 | 76.36 | 60 | 25 | 1210 | 1 | - | 25.5 | 1610 | 3 | - | 42.1 | 1210 | 5 |
| 17 | 93.0 | 86.36 | 71 | 25 | 1610 | 1 | - | 25.5 | 1610 | 3 | - | 42.1 | 1615 | 5 |
| 19 | 103.3 | 96.45 | 75 | 25 | 1610 | 1 | - | 25.5 | 1610 | 3 | - | 42.1 | 1615 | 5 |
| 21 | 113.4 | 106.52 | 76 | 25 | 1610 | 1 | - | 25.5 | 1610 | 3 | - | 42.1 | 2012 | 5 |
| 23 | 123.4 | 116.58 | 76 | 25 | 1610 | 1 | 90 | 32 | 2012 | 2 | 105 | 45 | 2517 | 4 |
| 25 | 134.0 | 126.66 | 90 | 32 | 2012 | 1 | 90 | 32 | 2012 | 2 | 110 | 45 | 2517 | 4 |
| 27 | 144.0 | 136.75 | 90 | 32 | 2012 | 1 | 90 | 32 | 2012 | 2 | 120 | 45 | 2517 | 4 |
| 30 | 158.8 | 151.87 | 90 | 32 | 2012 | 1 | - | - | - | - | - | - | - | - |
| 38 | 199.2 | 192.24 | 100 | 32 | 2012 | 1 | - | - | - | - | - | - | - | - |
| 45 | 235.0 | 227.58 | 100 | 32 | 2012 | 6 | - | - | - | - | - | - | - | - |
| *57 | 296.0 | 288.18 | 100 | 32 | 2012 | 6 | - | - | - | - | - | - | - | - |
| *76 | 392.1 | 384.16 | 100 | 32 | 2012 | 6 | - | - | - | - | - | - | - | - |
| *95 | 488.5 | 480.14 | 110 | 45 | 2517 | 6 | - | - | - | - | - | - | - | - |
| *114 | 584.1 | 576.13 | 110 | 45 | 2517 | 6 | - | - | - | - | - | - | - | - |

Taper Bore Sprockets



For Roller Chains DIN8187-ISO/R606

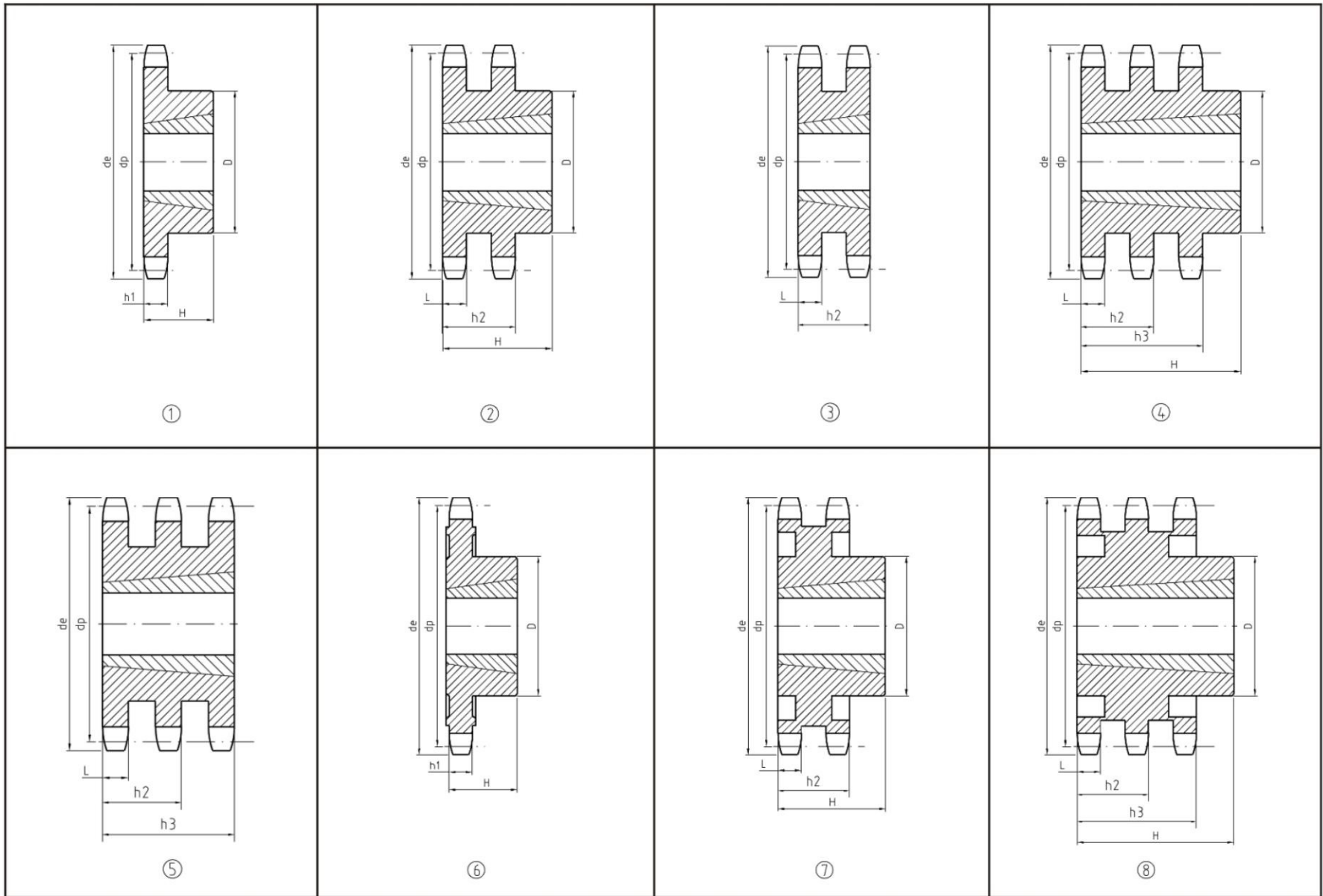

3/4" X7/16"

Steel=C45
*Cast iron=G22

12B-1-2-3 19.05X11.68mm DIN 8187 ISO/R 606

| CHAIN: | ISO mm |
|----------------|--------|
| Pitch | 19.05 |
| Internal width | 11.68 |
| Roller Φ | 12.07 |

| SPROCKETS | ISO mm |
|-------------------|--------|
| Tooth radius r | 19 |
| Radius width C | 2 |
| Tooth width h_1 | 11.1 |
| Tooth width L | 10.8 |
| Tooth width h_2 | 30.3 |
| Tooth width h_3 | 49.8 |

| Z | de | dp | TS | | | | TD | | | | TT | | | | | |
|------|-------|--------|-----|----|----------|------|-----|------|----------|------|-----|------|----------|------|---|---|
| | | | D | H | for Bush | Type | D | H | for Bush | Type | D | H | for Bush | Type | | |
| 13 | 87.5 | 79.59 | 60 | 25 | 1210 | 1 | - | - | - | - | - | - | - | - | - | - |
| 15 | 99.8 | 91.63 | 70 | 25 | 1610 | 1 | - | 30.3 | 1610 | 3 | - | 49.8 | 1615 | 5 | - | - |
| 17 | 111.5 | 103.67 | 76 | 25 | 1610 | 1 | - | 30.3 | 1610 | 3 | - | 49.8 | 1615 | 5 | - | - |
| 19 | 124.2 | 115.75 | 90 | 32 | 2012 | 1 | 90 | 32 | 2012 | 2 | - | 49.8 | 2012 | 5 | - | - |
| 21 | 136.0 | 127.82 | 102 | 45 | 2517 | 1 | 108 | 45 | 2517 | 2 | - | 49.8 | 2517 | 5 | - | - |
| 23 | 149.0 | 139.90 | 108 | 45 | 2517 | 1 | 108 | 45 | 2517 | 2 | - | 49.8 | 2517 | 5 | - | - |
| 25 | 160.0 | 152.00 | 108 | 45 | 2517 | 1 | 108 | 45 | 2517 | 2 | - | 49.8 | 2517 | 5 | - | - |
| 27 | 172.3 | 164.00 | 108 | 45 | 2517 | 1 | 108 | 45 | 2517 | 2 | 140 | 51 | 3020 | 4 | - | - |
| 30 | 190.5 | 182.25 | 108 | 45 | 2517 | 1 | 108 | 45 | 2517 | 2 | 140 | 51 | 3020 | 4 | - | - |
| 38 | 239.0 | 230.69 | 108 | 45 | 2517 | 1 | 140 | 51 | 3020 | 2 | 140 | 51 | 3020 | 4 | - | - |
| 45 | 282.5 | 273.10 | 108 | 45 | 2517 | 6 | 140 | 51 | 3020 | 7 | 140 | 51 | 3020 | 8 | - | - |
| *57 | 355.4 | 345.81 | 108 | 45 | 2517 | 6 | 140 | 51 | 3020 | 7 | 140 | 51 | 3020 | 8 | - | - |
| *76 | 469.9 | 460.99 | 108 | 45 | 2517 | 6 | 140 | 51 | 3020 | 7 | 140 | 51 | 3020 | 8 | - | - |
| *95 | 585.1 | 576.17 | 108 | 45 | 2517 | 6 | 140 | 51 | 3020 | 7 | 140 | 76 | 3030 | 8 | - | - |
| *114 | 700.6 | 691.36 | 108 | 64 | 2525 | 6 | 140 | 76 | 3030 | 7 | 140 | 76 | 3030 | 8 | - | - |

Taper Bore Sprockets



1" X17.02"

16B-1-2-3 25.4X17.2mm

DIN 8187 ISO/R 606

| CHAIN: | ISO mm |
|----------------|--------|
| Pitch | 25.4 |
| Internal width | 17.02 |
| Roller Φ | 15.88 |

| SPROCKETS | ISO mm |
|-------------------|--------|
| Tooth radius r | 26 |
| Radius width C | 2.5 |
| Tooth width h_1 | 16.2 |
| Tooth width L | 16.2 |
| Tooth width h_2 | 47.7 |
| Tooth width h_3 | 79.6 |

Steel=C45
*Cast iron=G22

Taper Bore Sprockets

| Z | de | dp | TS | | | | TD | | | | TT | | | |
|------|-------|--------|-----|----|----------|------|-----|------|----------|------|-----|------|----------|------|
| | | | D | H | for Bush | Type | D | H | for Bush | Type | D | H | for Bush | Type |
| 13 | 117.0 | 106.12 | 73 | 38 | 1615 | 1 | - | 47.7 | 2012 | 3 | - | 79.6 | 2517 | 5 |
| 15 | 133.0 | 122.17 | 76 | 38 | 1615 | 1 | - | 47.7 | 2517 | 3 | - | 79.6 | 3030 | 5 |
| 17 | 149.0 | 138.22 | 90 | 32 | 2012 | 1 | - | 47.7 | 2517 | 3 | - | 79.6 | 3030 | 5 |
| 19 | 165.2 | 154.33 | 108 | 45 | 2517 | 1 | 140 | 51 | 3020 | 2 | 159 | 89 | 3535 | 4 |
| 21 | 181.2 | 170.43 | 110 | 45 | 2517 | 1 | 140 | 51 | 3020 | 2 | 175 | 89 | 3535 | 4 |
| 23 | 197.5 | 186.53 | 110 | 45 | 2517 | 1 | 140 | 51 | 3020 | 2 | 175 | 89 | 3535 | 4 |
| 25 | 213.5 | 202.66 | 110 | 45 | 2517 | 1 | 140 | 51 | 3020 | 2 | 175 | 89 | 3535 | 4 |
| 27 | 229.6 | 218.79 | 110 | 45 | 2517 | 1 | 140 | 51 | 3020 | 2 | 175 | 89 | 3535 | 4 |
| 30 | 254.0 | 243.00 | 140 | 51 | 3020 | 1 | 140 | 76 | 3030 | 2 | 175 | 89 | 3535 | 4 |
| 38 | 320.7 | 307.59 | 140 | 51 | 3020 | 1 | 140 | 76 | 3030 | 2 | 175 | 89 | 3535 | 4 |
| 45 | 377.1 | 364.13 | 140 | 51 | 3020 | 6 | 140 | 76 | 3030 | 7 | 215 | 102 | 4040 | 8 |
| *57 | 474.0 | 461.07 | 140 | 51 | 3020 | 6 | 175 | 89 | 3535 | 7 | 215 | 102 | 4040 | 8 |
| *76 | 627.0 | 614.65 | 140 | 51 | 3020 | 6 | 175 | 89 | 3535 | 7 | 215 | 102 | 4040 | 8 |
| *95 | 781.1 | 768.22 | 140 | 51 | 3020 | 6 | 215 | 102 | 4040 | 7 | 215 | 102 | 4040 | 8 |
| *114 | 934.3 | 921.81 | 140 | 76 | 3020 | 6 | 215 | 102 | 4040 | 7 | 260 | 114 | 4045 | 8 |

1" 1/4X3/4"

20B-1-2-3 31.75X19.56mm

DIN 8187 ISO/R 606

| CHAIN: | ISO mm |
|----------------|--------|
| Pitch | 31.75 |
| Internal width | 19.56 |
| Roller Φ | 19.05 |

| SPROCKETS | ISO mm |
|-------------------|--------|
| Tooth radius r | 32 |
| Radius width C | 3.5 |
| Tooth width h_1 | 18.5 |
| Tooth width L | 18.2 |
| Tooth width h_2 | 54.6 |
| Tooth width h_3 | 91 |

Steel=C45
*Cast iron=G22

| Z | de | dp | TS | | | |
|-----|-------|--------|-----|----|----------|------|
| | | | D | H | for Bush | Type |
| 13 | 147.8 | 132.65 | 90 | 32 | 2012 | 1 |
| 15 | 167.9 | 152.72 | 108 | 45 | 2517 | 1 |
| 17 | 187.9 | 172.78 | 108 | 45 | 2517 | 1 |
| 19 | 208.1 | 192.91 | 108 | 45 | 2517 | 1 |
| 21 | 228.2 | 213.04 | 108 | 45 | 2517 | 1 |
| 23 | 248.3 | 233.17 | 108 | 45 | 2517 | 1 |
| 25 | 268.5 | 253.33 | 108 | 45 | 2517 | 1 |
| 27 | 288.6 | 273.40 | 150 | 51 | 3020 | 1 |
| 30 | 318.9 | 303.75 | 150 | 51 | 3020 | 1 |
| 38 | 399.6 | 384.49 | 160 | 51 | 3020 | 6 |
| *45 | 470.3 | 455.17 | 160 | 51 | 3020 | 6 |
| *57 | 591.5 | 576.36 | 160 | 51 | 3020 | 6 |
| *76 | 783.5 | 768.32 | 160 | 51 | 3020 | 6 |